

Bradma[®]
Automating The Future

CONVENTIONAL MARKING SOLUTIONS

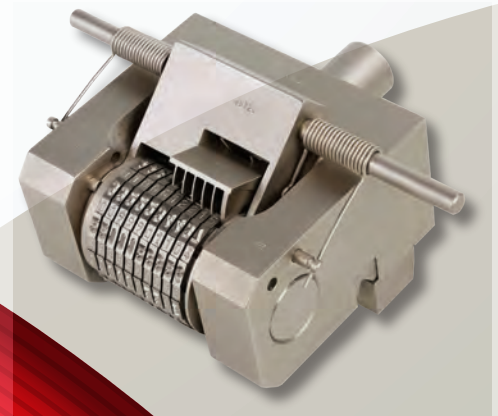
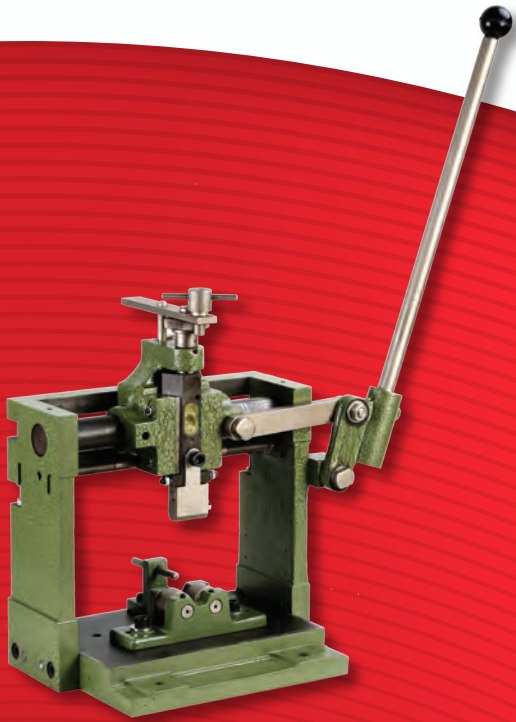

Because High Quality Products
Must Have High Quality Markings

WHY MARK?

- ▶ Permanent Indentation
- ▶ Easy Identification
- ▶ Neat Marking Suggests Quality
- ▶ Accurate & Legible Part Nos. Model Nos. etc. Facilitate replacement and repairs.
- ▶ Clear Easy to Read Patent Numbers Protect against infringement.
- ▶ Advertise Trade Name

WHAT TO MARK?

- ▶ Part Numbers
- ▶ Serial Numbers
- ▶ Size
- ▶ Model Identification
- ▶ Graduations
- ▶ Batch Number
- ▶ Material Code
- ▶ Inspector's Code
- ▶ Date Code
- ▶ Instructions to User
- ▶ Name Plate Details

METHODS OF MARKING

Rectangular - Body Based

Types

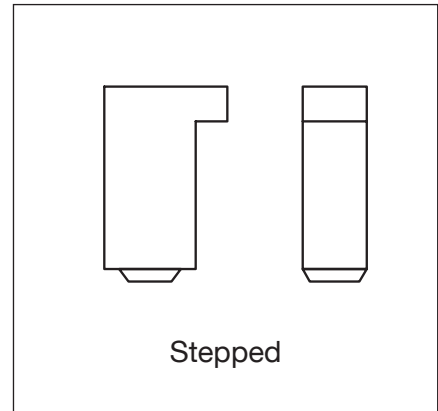
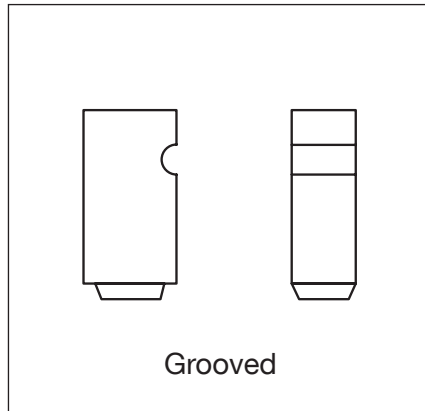
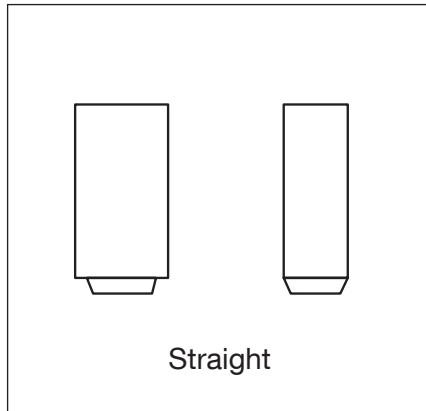

Stamp Marks (Composite Types)

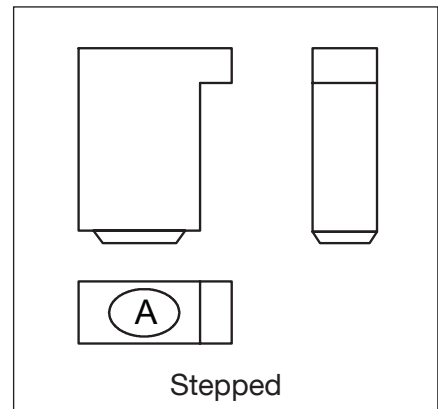
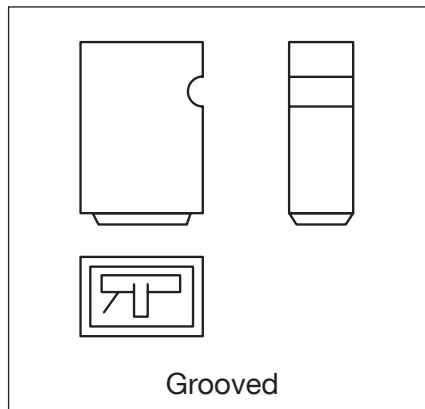
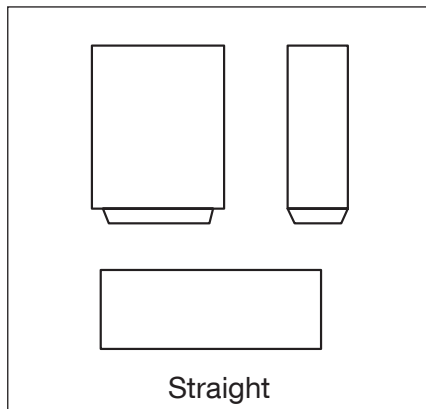

- ▶ Hand Held Punches
- ▶ Inter Changeable Steel Types
- ▶ Stamp Marks
- ▶ Rotary Type Numerators

Steel Types - Rectangular Body

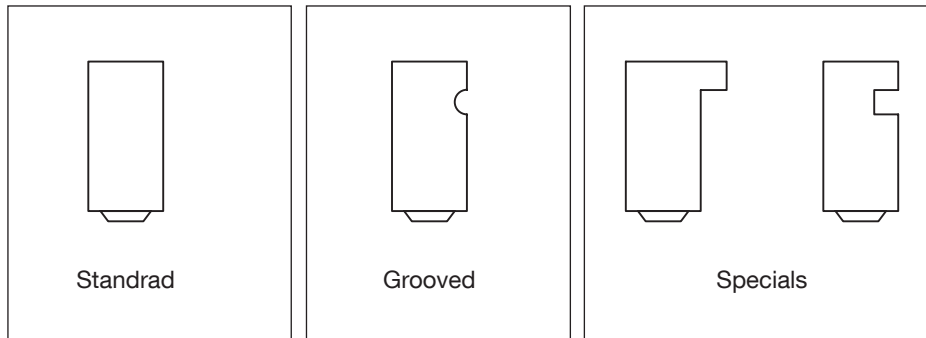

Inch Series

- ▶ Sizes 1/16, 3/32, 1/8, 3/16, 1/4, 3/8

Main Features

- ▶ Common Body Size 8x0.25
- ▶ Same Holder can be used for all types

Metric Series

- ▶ Sizes (mm) 1, 2, 3, 4, 5, 6, 8, 10

Grooved Types

Metric Series

- ▶ Sizes 1, 2, 3, 4, 5, 6, 8, 10

Advantages

- ▶ Groove Prevents Types from falling out of Holder
- ▶ Heavy Marking on Castings
- ▶ Heavy Marking on Forging
- ▶ Hot Bullet Marking

Label Marking

- ▶ Sizes 1.6, 2 mm

Main Features

- ▶ Special L-Shaped Section
- ▶ No Restriction on Label Layout

Coding System

ABBREVIATIONS	
T - TYPES	1/16 = .062
S- SPACERS	3/32 = .093
B- BOX	1/6 = .125
H - HAND HOLDER	3/16 = .187
M - MACHINE HOLDER	1/4 = .250
R - REVERSE TYPES	3/8 = .375

Types

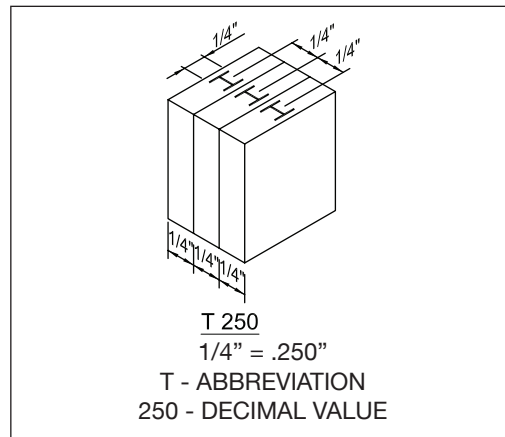
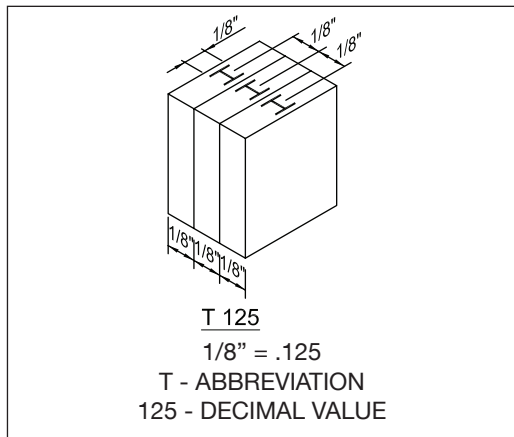

Coding System

Boxes

1.112BH 187	3.66BH 375
112 100 TYPES + 12 SPACERS	66 60 TYPES + 6 SPACERS
B ABBREVIATION FOR BOX	B ABBREVIATION FOR BOX
H ABBREVIATION FOR HOLDER	H ABBREVIATION FOR HOLDER
187 DECIMAL VALUE OF 3/16	375 DECIMAL VALUE OF 3/8

Set Code No.		Type Code No.	Holder Code No.
With Holder	Without Holder		
112 BH 062	112 BH 062	T 062	125 H 750
112 BH 093	112 BH 093	T 093	250 H 1000
112 BH 125	112 BH 125	T 125	250 H 1250
112 BH 187	112 BH 187	T 187	312 H 1250
112 BH 250	112 BH 250	T 250	375 H 1500
66 BH 375	66 BH 375	T 375	625 H 2250

MARKING METHODS

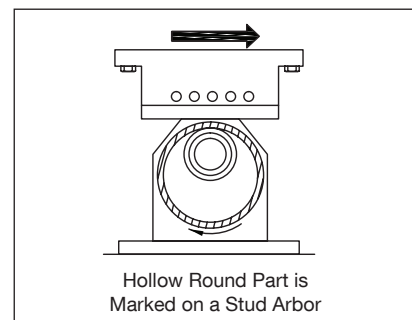
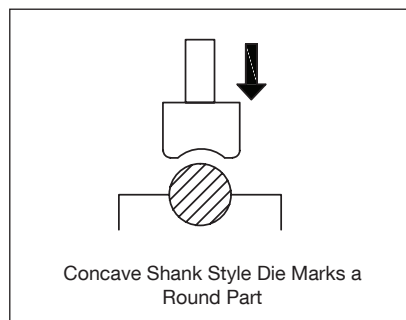
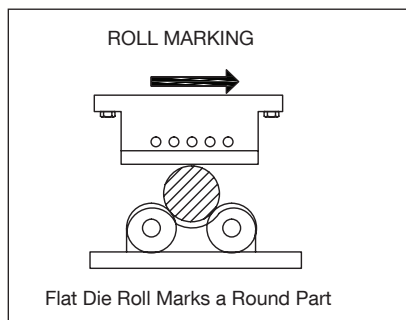
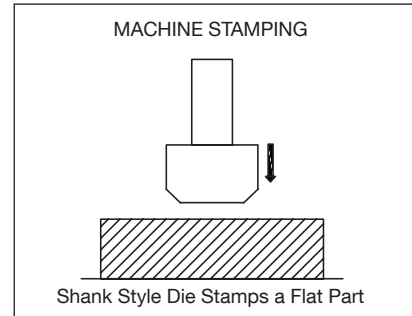
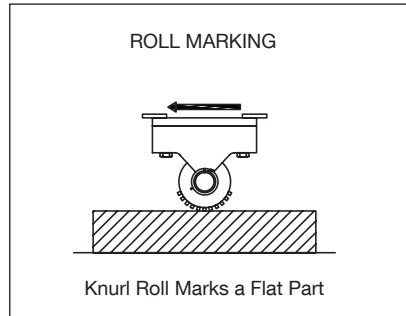
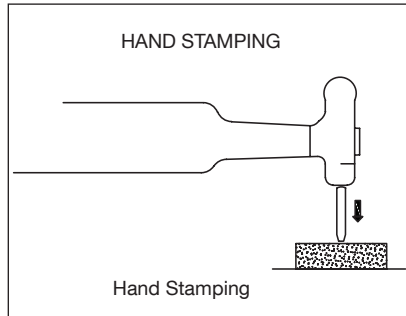

Character Face

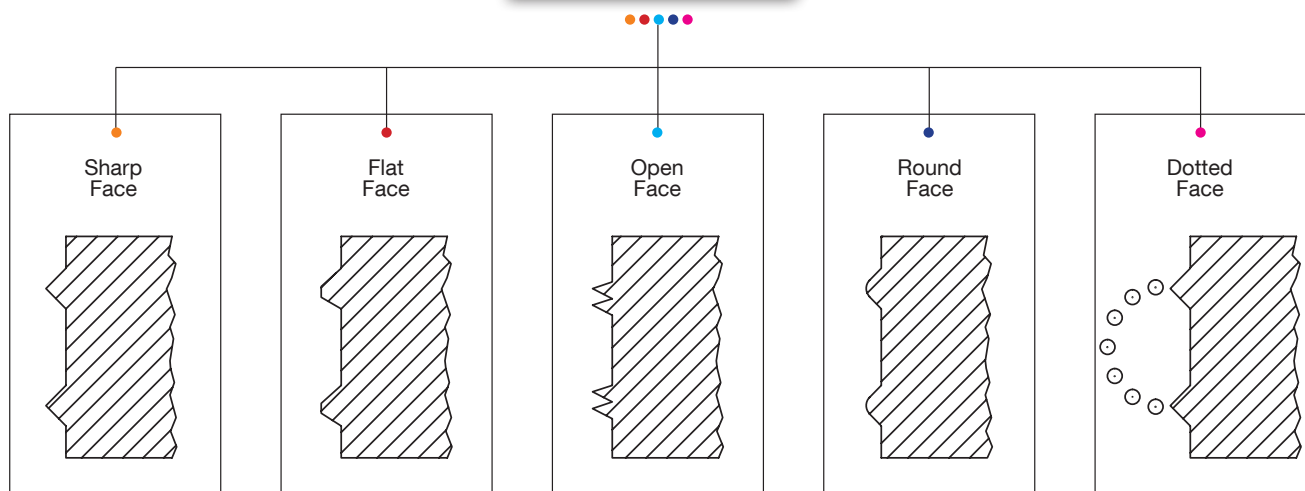

BRADMA DIE HARD INTERCHANGEABLE STEEL TYPES (ISTs)



Standard Fount Sets

Alpha-Numeric Set - With or Without Holder

Bradma Type Code No.	Character Size D Mm	Type Size			Bradma Fount Set Code No.		Number of Types In Set	Number of Spacers Set	Bradma Hand Holder Code	Bradma Hand Holder Capacity
		A MM	B MM	C MM	With Hand Holder	Without Hand Holder				
T 010	1.00	1.00	8.00	25.00	112BH010	112B010	100	12	8 H 20	20
T 062	1.59 (1/16")	1.59	3.18	15.88	112BH062	112B062	100	12	125H750	12
T 020	2.00	2.00	8.00	25.00	112BH020	112B020	100	12	8 H 25	12
T 093	2.40 (3/32")	2.40	6.35	19.05	112BH093	112B093	100	12	250H1000	10
T 030	3.00	3.00	8.00	25.00	112BH030	112B030	100	12	8H25	8
T 125	3.18 (1/8")	3.18	6.35	19.05	112BH125	112B125	100	12	250H1250	10
T 040	4.00	4.00	8.00	25.00	112BH040	112B040	100	12	8H40	10
T 187	4.76 (3/16")	4.76	7.94	19.05	112BH187	112B187	100	12	312H1250	6
T 050	5.00	5.00	8.00	25.00	112BH050	112B050	100	12	8H40	8
T 060	6.00	6.00	8.00	25.00	112BH060	112B060	100	12	8H40	6
T 250*	6.35 (1/4")	6.35	9.53	19.05	112BH250	112B250	100	12	375H1500	6
T 080*	8.00	8.00	14.00	25.00	66BH080	66B080	60	6	14H60	7
T 375*	9.53(3/8")	9.53	15.88	25.40	66BH375	66B375	60	6	625H2250	6
T 100*	10.00	10.00	14.00	25.00	66BH100	66B100	60	6	14H60	6
T160*	16.00	12.00	20.00	30.00	-	-	-	-	-	-

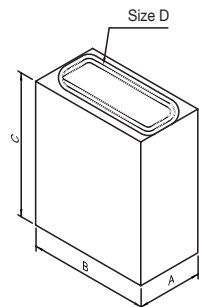

Items with codes marked as * are made to order

Number Set Without Holder

BRADMA TYPE CODE NO.	CHARACTER SIZE D MM	TYPE SIZE			BRADMA FOUNT SET CODE NO.	NUMBER OF TYPES IN SET	NUMBER OF SPACERS SET
		A MM	B MM	C MM			
T 062	1.59 (1/16")	1.59	3.18	15.88	56 BN 062	50	6
T 020	2.00	2.00	8.00	25.00	56 BN 020	50	6
T 093	2.40 (3/32)	2.40	6.35	19.05	56 BN 093	50	6
T 030	3.00	3.00	8.00	25.00	56 BN 030	50	6
T 125	3.18 (1/18")	3.18	6.35	19.05	56 BN 125	50	6

Composition of 112 Types Set (for upto 6.35 or 1/4")

A	A	A	B	B	C	C	D	D	E	E	E	E	F	F	G	G	H	H	I
I	I	J	J	K	K	L	L	L	M	M	N	N	N	O	O	O	P	P	Q
R	R	R	S	S	S	T	T	U	U	U	V	W	W	X	X	Y	Z	&	/
/	_	_	1	1	1	1	2	2	2	2	3	3	3	4	4
4	4	5	5	5	6	6	6	7	7	7	8	8	8	9	9	9	0	0	0
SP	SP	SP	SP	SP	SP	SP	SP	SP	SP	SP	SP								

Composition of 66 Types Set (for upto 6.35 or 1/4")

A	B	C	D	E	F	G	H	I	J	K	L	M	N	O
P	Q	R	S	T	U	V	W	X	Y	Z	1	1	1	2
2	2	3	3	3	4	4	4	5	5	5	6	6	6	7
7	7	8	8	8	9	9	9	0	0	0	/	_	.	.
SP	SP	SP	SP	SP	SP									

Composition of 56 Types Set (for above 6.35 or 1/4")

0	0	0	0	0	0	0	0	0	0	1	NEW			
1	1	1	1	2	U	2	2	2	2	3				
3	3	3	3	4	4	4	4	4	4	5				
5	5	5	5	6	9	6	6	6	7	7				
7	7	8	8	8	8	9	9	9	9	9				
SP	SP	SP	SP	SP	SP	SP								

- ▶ Suitable for part numbering, batch & date coding, etc. on Steels, Casting, Forgings, Aluminum, Brass, Plastics, Paper.
- ▶ Types made from High Quality Tool Steel
- ▶ Letters and Numbers formed by unique cold forming process for longer tool life
- ▶ Dull Nickel plated for rust free longer shelf life.
- ▶ Bevel Angles, Character Depth & “Bradma” Calligraphy to maximize type life
- ▶ Sets are available with or without Holder.
- ▶ All dimensions are to very close tolerances, for the clearest uniform impression in perfect alignment

What are Interchangeable Steel Types

- ▶ Steel Types which can be composed like Printer’s Types
- ▶ Made of Alloy Steel
- ▶ Hardened and Tempered to give
 - a) Toughness
 - b) Wear Resistance
- ▶ Plated to Resist Rust
- ▶ Character Accurately Positioned on Shank
- ▶ Overall Length Controlled-Uniform Depth
- ▶ Can be easily Composed-Uniform Depth
- ▶ Can be easily Composed in Holders suitable for Hand or Machine Operation

Marking Elements (Steel Types - Rectangular Body)

Special Types - They can be developed if:

- ▶ Calligraphy & Character Sizes are from our Standard Range.
- ▶ Manufacture of Special Types is Compatible with our Type Forming Process.
- ▶ Volumes are sufficiently large.

Bradma Special Interchangeable Types

- ▶ Segmental, Radial, Grooved and Stepped Types for special applications
- ▶ Low Stress Types
- ▶ Concave or Convex Types
- ▶ Types with Special Calligraphy design
- ▶ Types for Hot Stamping applications
- ▶ Special Types for Blister Packing, Cartonators, Collapsible Tubes, Crimping, Sachets, Tetra packs etc.

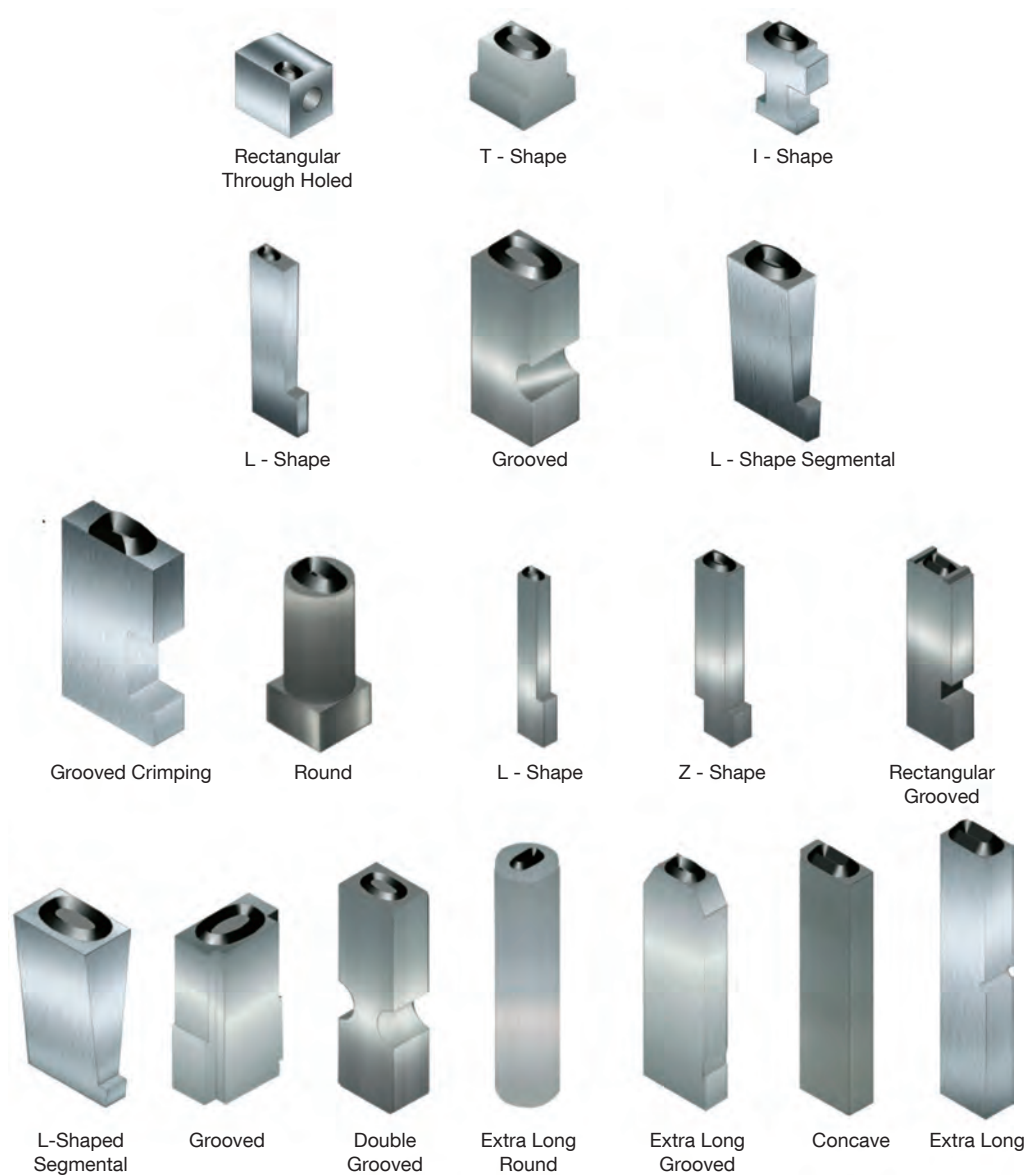

HAND HOLDER

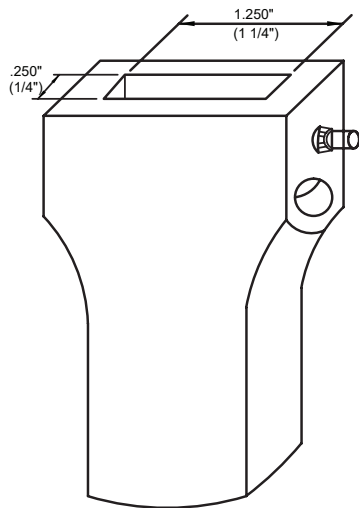

250 M 1250
 250 : WIDTH OF SLOT IS 1/4"
 H : ABBREVIATION FOR HAND HOLDER
 1250 : LENGTH OF SLOT

MACHINE HOLDER

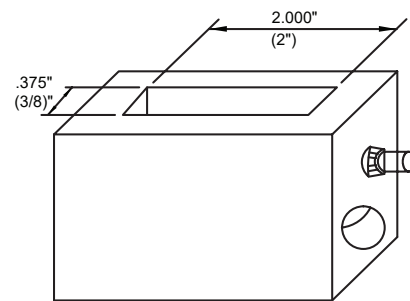

375 M 2000
 375 : WIDTH OF SLOT 15 3/8"
 M : ABBREVIATION FOR MACHINE HOLDER
 2000 : LENGTH OF SLOT

HOLDER C. NO.	TYPE C. NO.	NO. OF LINES	CAPACITY PER LINE
125 BH 750	T062	1	12
250 H 2L 1000	T062	2	12
250 H 1000	T093	1	10
250 H 1000	T125	1	8
250 H 1250	T093	1	13
250 H 1250	T125	1	10
312 H 1250	T187	1	6
375 H 1500	T250	1	6
625 H 2250	T375	1	6

BRADMA DIE HARD TYPE HOLDERS



HOLDER CAPACITY - NUMBER OF TYPES (TYPE SIZE MM)

HAND HOLDER BRADMA CODE NO.	1.00	1.59 (1/6")	2.00	2.40 (3/32")	3.00	3.18 (1/8")	4.00	4.76 (3/16")	5.00	6.00	6.35 (1/4")	8.00	9.53 (3/8")	10.00
8 H 20	20		10		6		5							
8 H 25			12		8		6		5	4				
8 H 40					13		10		8	6				
14 H 60												7		6
125 H 750		12												
250 H 1000				10										
250 H 1250				13		10								
312 H 1250								6						
375 H 1500														
625 H 1500											6			
250 H 2L 1000		24*											6	

MACHINE HOLDER CAPACITY - NUMBER OF TYPES (TYPE SIZE MM)

MACHINE HOLDER BRADMA CODE NO.	1.00	1.59 (1/6")	2.00	2.40 (3/32")	3.00	3.18 (1/8")	4.00	4.76 (3/16")	5.00	6.00	6.35 (1/4")
8 M 20	20		10		6		5				
8 M 40	40		20		13		10		8	6	
8 M 60			30		20		15		12	10	
8 M 80					26		20		16	13	
125 M 1000		16									
125 M 2000		32									
250 M 1000				10		8					
250 M 2000				21		16		10			
250 M 3000				32		24					
312 M 3000											
375 M 2000											8
375 M 3000											12

§ SPECIAL 2-LINE, 3 LINE, 4 LINE & HOLDERS with Special Slot Sizes available on request.

Salient features of Bradma Type Holders

- ▶ Designed for accurate Type location and Type alignment.
- ▶ Positive locking of Types.
- ▶ Enable Quick change of Type & high Interchangeability.

BRADMA DIE HARD TYPE PUNCHES

Loose Hand Punches

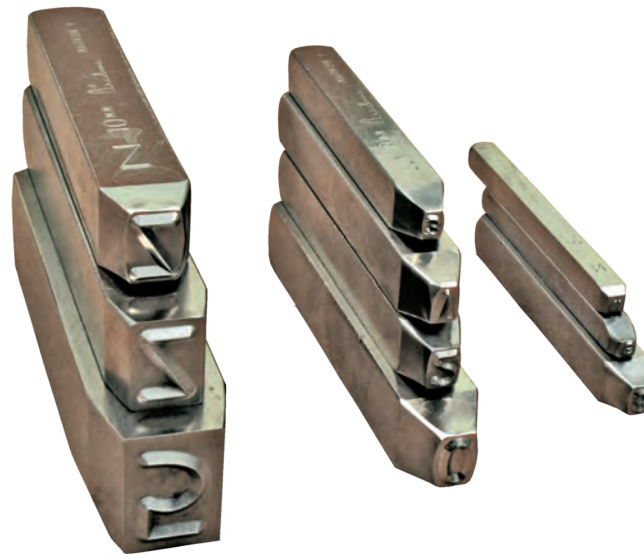

HAND PUNCH SETS

CHARACTER SIZE mm	ALPHA SET A TO Z Bradma Code No.	NUMBER SET 0 TO Bradma Code No.
1.6	26HHP 062	9HHP 062
2	26HHP 020	9 HHP 020
2.4 (3/32")*	26HHP093*	9 HHP 093*
3	26HHP030	9 HHP 030
3.148 (1/8")*	26HHP125*	9 HHP125*
4	26HHP040	9 HHP040
5	26HHP050	9 HHP050
6	26HHP060	9 HHP060
6.35 (1/4")*	26HHP250*	9 HHP 250*
8	26HHP 080	9 HHP 080
9.53 (3/8")*	26HHP375*	9 HHP375*
10	26HHP100	9HHP100
12	26HHP120	9HHP120
12.7 (1/2")*	26HHP500*	9HHP500*
16*	26HHP160*	9HHP160*
20*	26HHP200*	9HHP200*

- ▶ Items marked as (*) are Made to Order
- ▶ Alpha Sets of 27HHP are also available on request for all the sizes with Character "&" included in the set.

Alpha Set A-Z



Number Set 0-8



MARKING ELEMENTS

Bradma Die Hard Hand Punches

- ▶ Made from high quality, heat treated tool steel. Finely balance with liberal overall shank size.
- ▶ Ensures deep, clear and legible stamped impression, Safeguards against mushrooming, chipping and splitting of hammering hard.
- ▶ Each punch is clearly marked with character designation and size.

Bradma Special Hand Punches

- ▶ Low Stress hand Punches.
- ▶ Special Calligraphy on request.
- ▶ Extra Long hand punches.
- ▶ Convex/Concave faces.
- ▶ Reverse Alphabets & Numbers for forging and die casting dies and for rubber moulds.
- ▶ Hand punches with Logos.

Hand Held Punches

Bradma punches

- ▶ Use of tool steel, not plain carbon steel. Can mark on hard surfaces 35-38 HRC.
- ▶ Type formed characters uniformity
- ▶ Nickel plated for corrosion prevention.
- ▶ Will meet IS : 6864-1984 (1st revision) which is very rigorous.

Rotary Numerators

Hand Numerator

Size Developed - 2,3,4 & 5 mm

- ▶ 6 RTN2, 6RTN3, 6HN4, 5YHN5

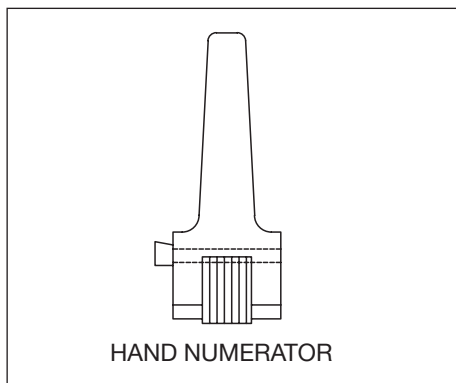

Wheel Configuration

- ▶ 0 to 9 Numerals
- ▶ Special Configuration Consisting of Alphas can be offered.

New improved design is being introduced for 4 mm to 5 mm sizes.

- ▶ Each Wheel can be indexed separately without disturbing adjacent wheels
- ▶ Indexing pin does not fall out
- ▶ Better Hand Grip
- ▶ Rugged Body

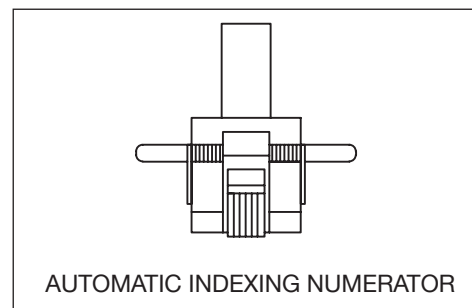
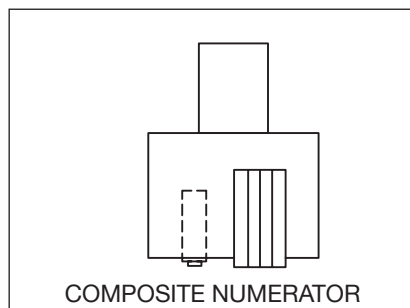
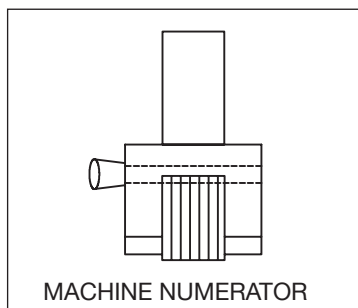

HAND HELD ROTARY TYPE NUMERATOR



- ▶ Perfect for part numbers or Code numbers making by hand stamping on Casting, Steel, Brass, Aluminium.

Salient features of Bradma Rotary Type Numerators

- ▶ Each Marking wheel has 11 faces with 0 to 9 figures on 10 faces and one face blank.
- ▶ Marking Wheel can be rotated to any desired position, then locked positively by a locking pin.
- ▶ Individual wheel release : One wheel can be released at a time, without disturbing set-up of other wheels.

Special Rotary Type Numerators

- ▶ Rotary Type Numerators with wheel combinations of Alpha-Numeric Wheels.
- ▶ Rotary Type Numerators with provisions to mark Logo / fixed Letters along with numbers.
- ▶ Special Numerators with concave / convex wheels to mark on curved surfaces.
- ▶ Special wheels for Hot Stamping.

BRADMA RTN CODE NO. WITH HAND HOLDER	BRADMA RTN CODE NO. WITH MACHINE HOLDER	CHARACTER SIZE MM	CHARACTER SPACING MM	NO. OF WHEELS 0-9	MARKED LENGTH
6RTN 2	6RTN 2M	2	2	6	11.2
6RTN 3	6RTN 3M	3	3	6	16.8
6RTN 3	6RTN 4M	4	4	6	22.4
7RTN 4*	7RTN 4M*	4	4	7	26.4
5RTN 5*	5RTN 5M*	5	5	5	23.0
6RTN 5*	6RTN 5M*	5	5	6	28.0

BRADMA DIE HARD AUTOMATIC ROTARY NUMERATOR



- ▶ SERIAL NUMBERS can be marked on metal parts - in a simple operation. Special design ensures that numbers advance one at a time accurately and automatically.

Salient features of Bradma Rotary Type Numerators

- ▶ Wheels made from special Tool Steel
- ▶ Advancing cams machined into solid wheels
- ▶ Cam material as durable as stamping characters
- ▶ Extra wide unit wheel for longer life
- ▶ One - piece actuating pawl machined from solid bar
- ▶ Direct - reading characters to check set-up
- ▶ No rivetted assembly - easy to dismantle and clean by user
- ▶ Unique design of holding catch and springs

Special Automatic Rotary Numerators

- ▶ Automatic Rotary Numerators with more than 10 wheels
- ▶ Numerators with Alpha - Numeric and / or special wheel combination
- ▶ Concave / Convex Numerators for Curved Surfaces
- ▶ High Performance Numerators for longer life
- ▶ Composite Numerators with provision to mark Logo or Repeated fixed data along with serial numbers
- ▶ Numerators for marking at Red Hot temperature or Numerator with Heating arrangement
- ▶ Numerators with special Calligraphy

Indicate exact spread or Height of stamping data

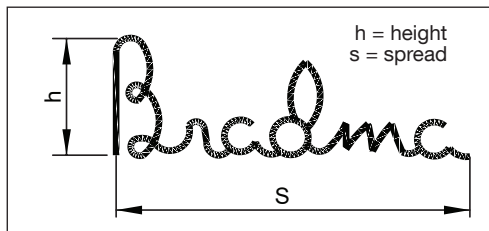

Select Blank size

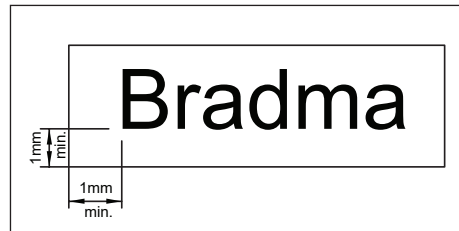

Standard engraving depth is 0.25 mm

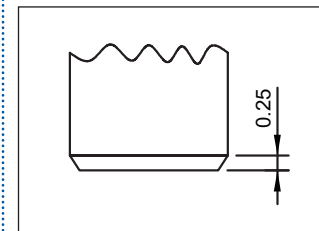

If extra depth or less depth is needed then specify in the enquiry with reasons.

Some of the reasons are as follow.

- a. Deeper stamping is required on some products
e.g. Spanners, Electric Tower frames, etc.
- b. After stamping machining is to be done.

Positioning of marking data on the blank.

- a. Generally stamping data is centralised on on the blank.
- b. In special cases it is necessary to bias the stamping data

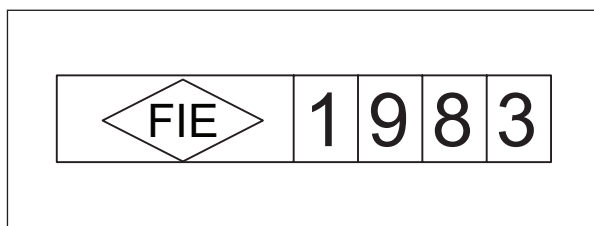

Points to Remember

- ▶ Only Thickness & Width dimensions for Calligraphy.
- ▶ Engraving Depth will not be more than 0.25mm.
- ▶ If Nothing Is specified in order then
 - a. Engraving depth =0.25mm character damage
 - b. Stamping data will be centralised.
 - c. Smaller dimensions of marking data will be placed along smaller dimensions of the blank.
 - d. Bigger dimensions of marking data will be placed along bigger dimensions of the blank.
- ▶ Indicate the desired orientation of marking data with respect to shank.
- ▶ Specify starting dimensions if necessary.
- ▶ Give careful thought to the orientation of SM In holder slot.

INFORMATION TO INCLUDE WITH YOUR ORDER / ENQUIRY

- ▶ Drawing of Component
 - a. Material
 - b. Hardness – at Marking Stage
 - c. Location of Marking
 - d. Physical Dimensions
 - e. Subsequent machining operation on marked face, If any
 - f. Lettering Detail – size and style
- ▶ Marking Method:
 - a. Hand Stamping
 - b. Machine Stamping
 - c. Roll Marking
- ▶ Production Requirements
- ▶ Samples of Components

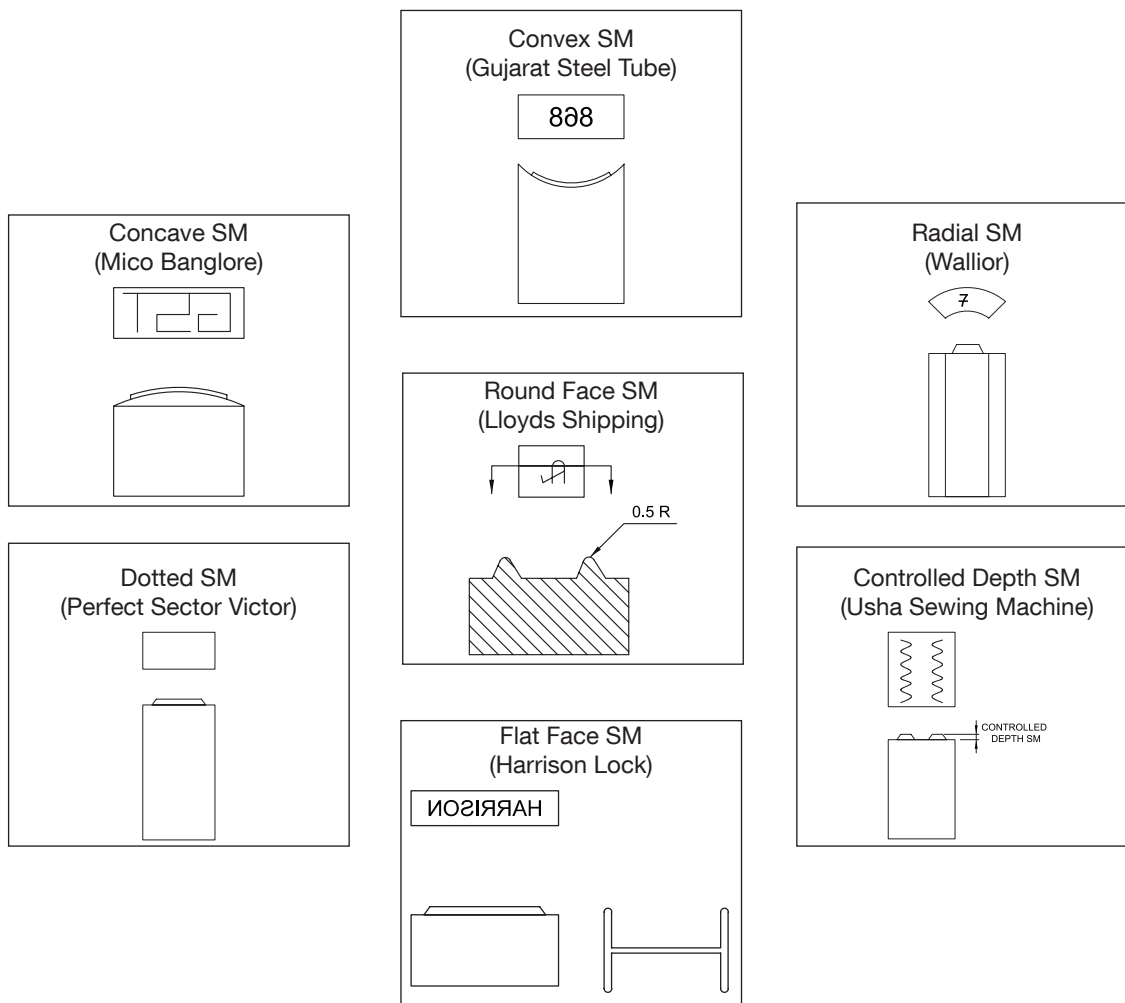

SAMPLE VARIETIES OF STAMP MARKS

SINGLE LINE

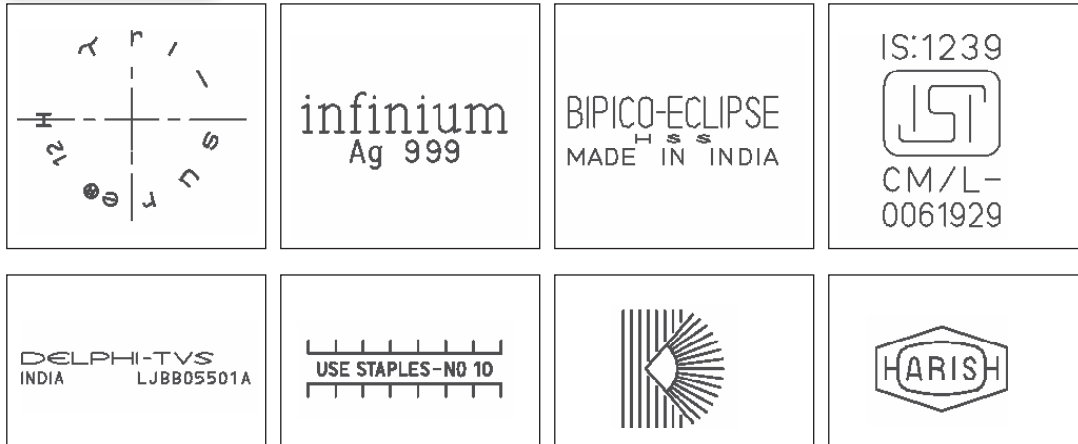

BOLD

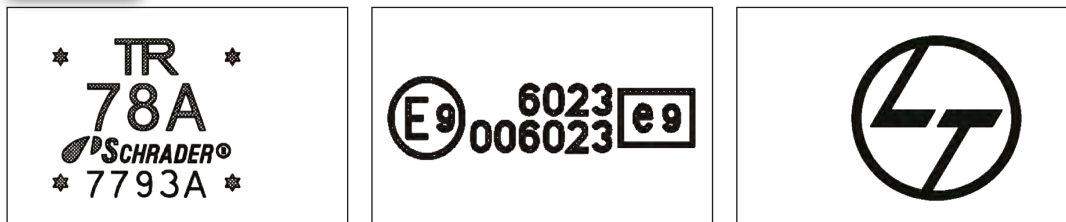

DOUBLE LINE



LOW STRESS STAMP MARKS

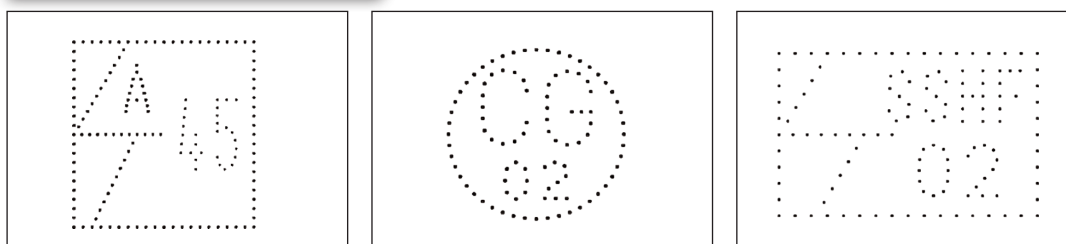

INSPECTION STAMP MARKS

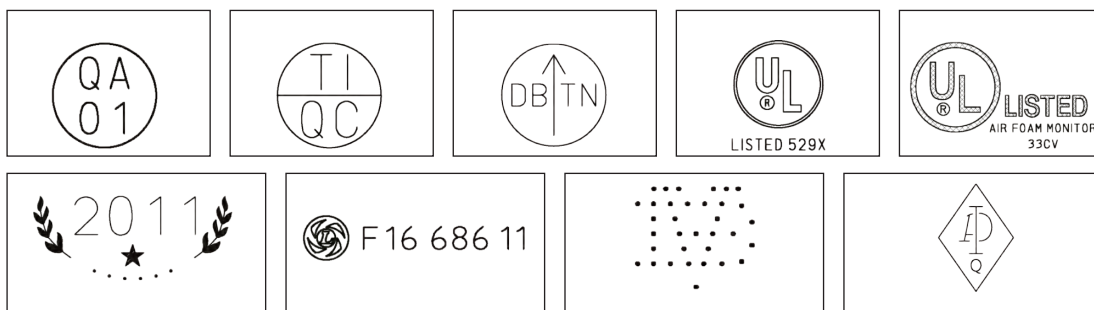

BRADMA DIE HARD IMPACT PRESS

- ▶ Easy-to-adjust impact force.
- ▶ Automatic compensation for different workpiece thickness (Note: Airline Pressure is only compressing the spring - not for determining impact force).
- ▶ Highly versatile : Ideal for LIGHT ASSEMBLY WORK and for SHEET METAL WORK (Rivetting, flaring, Piercing, Shearing, Bending, crimping etc)
- ▶ Output speed matches speed of manual loading.
- ▶ Lowest rejections - even in precision jobs.
- ▶ Far longer tool / die life.
- ▶ Adaptable for automation with appropriate fixtures tools and dies.
- ▶ Tools with cylindrical shanks are clamped by a collet in tool-holder.
- ▶ Arm can be set and clamped at any height on the column.
- ▶ Fine-ground working table surface with T-slots for speedy fitting of work - holding fixtures.
- ▶ Depth of marking does not vary if component thickness varies.
- ▶ Capacity to Mark : 1/16" Size - 16 Character, 1/8" Size - 8 character



Specifications

MODEL	IP28PN	IP28H
CAPACITY	2.5 T	2.8 T
DAYLIGHT	273 mm	273 mm
THROAT	140 mm	140 mm
TABLE SIZE	160 X 160 mm	160 X 160 mm
COLUMN	60 mm dia	60 mm dia
COLLET	10 mm	10 mm
AIR LINE PRESSURE	5 kg / sq cm	--
NET WEIGHT	60 kg	55 kg

BRADMA DIE HARD METAL LABEL MARKER

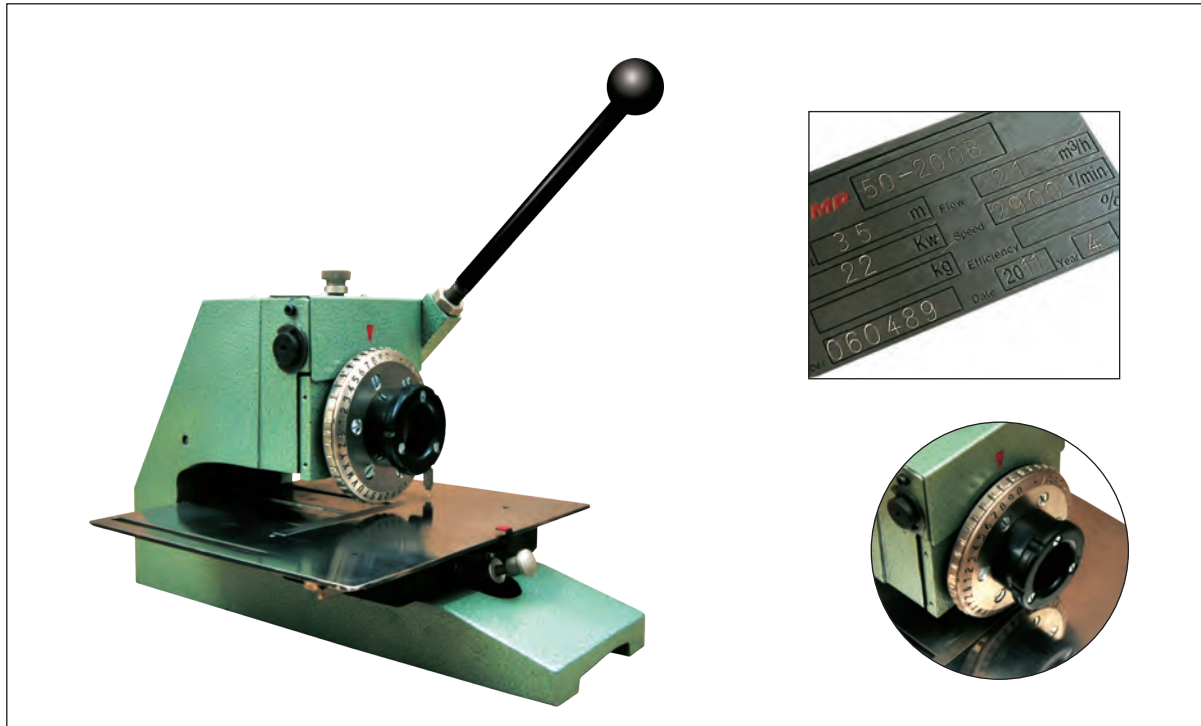

BRADMA CODE	CHARACTER SIZE
LM 40/1.6	1.6 MM
LM 40/2	2 MM
LM 40/3	3 MM
LM 40/4	4 MM

Special Features

Leaf gauge for multi-line labels. This special leaf-gauge can be custom-built to your individual need. It enables speedy alignment of each lines before marking. After marking a line, a leaf is flipped for immediate setting to mark in the next line. Stops for 2-lines labels Specially for 2-line marking, there are two stops (supplied with machine) to enables faster, accurate automatic alignment of each line before marking.

Features



- ▶ MARKS WIDE RANGE OF LABELS/TAG perfectly marks Aluminium, Brass, Steel almost every metal (especially effective in marking into windows of pre-printed labels)
- ▶ SHARP CLARITY SAYS HIGH QUALITY All marked data is sharply clear and easy-to-read; accurately aligned, evenly spaced and uniformly deep.
- ▶ PRECISION ENGINEERED has a rugged cast iron frame, specially hardened ground steel components and a unique dial wheel construction with interchangeable type inserts. Every feature is designed and engineered for long, trouble - free service.
- ▶ VERSATILITY ideal when a wide range of label sizes need marking, when marking data varies, and when short production runs are required.
- ▶ LOW COST TOO Bradma Diehard Metal Label Marker is a high precision tool which means virtually no label spoilage, virtually no rejections. Result: Marking cost is considerably lower than by tedious unreliable hand - stamping methods.

ENGINEERED FOR LONG LIFE AND LASTING PRECISION

BASIC 5-STEP OPERATION

1. Simply set for marking depth.
2. Locate label on marking table.
3. Rotate dial wheel to select the character to be marked.
4. Depress operating handle to mark label.
5. Release operating handle - and the table automatically advances the label to the next marking position.

Specifications

LABEL CAPACITY	upto 100 mm deep and 200 mm wide
LABEL THICKNESS	0.3 mm to 2.5 mm 10 mm minimum and 95 mm maximum from top edge of label
MARKING LIMITS	10 mm minimum and 95 mm maximum from top edge of label
TABLE SIZE	240 X 90 mm
TABLE TRAVEL	125 mm from right to left
CHARACTERS ON DIAL WHEEL	A to Z
DIAL WHEEL	0 thru' 9 . - / &
NET WEIGHT	15 kg.

BRADMA DIEHARD ROLL MARKING MACHINE



Features

- ▶ Ideal for marking cylindrical (Solid or Hollow) components of Steel, Aluminium, Brass etc. using Bradma Interchangeable Steel Types and marking Dies.
- ▶ Perfect for marking such specific components as drills, taps, engine valves, spark plugs, cutting tools, diamond tools, bushes, nozzles, sanitary fittings, hose end fittings, gas lighters and studs.
- ▶ Outstanding benefits : Low set -up time. Easy operation. High output rates. Robust construction low costs (uses standard low set -up time).
- ▶ The Steel Types or stamp marks are mounted in holder fixed to the machine carriage.
- ▶ A simple hand lever operates the carriage producing a uniform, legible marking.
- ▶ Marking depth is precisely set by adjusting the vertical dove-tail slide, which cant then be locked any position for for repetitive work.

Note: The length of inscription, size of characters number of lines and depth of impression are interrelated and also depend on the hardness of the material being marked.

ACCESSORIES

Anvil, Roller Cradle, Stud Arbour, Type Holder.

ANVIL

Components to be marked can be placed either on the Anvil or directly on the Bed.

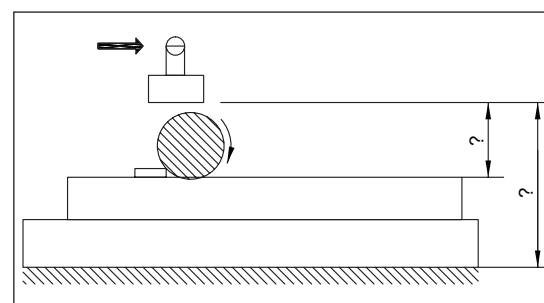

PRINCIPLE OF OPERATION

TYPE	CHARACTER SIZE MM	MARKING DIE TO ANVIL 'A'		MARKING DIE TO BED 'B'		MARKING DIE TO ANVIL 'A'		MARKING DIE TO 'B'	
		MAX. MM	MIN. MM	MAX. MM	MIN. MM	MAX. MM	MIN. MM	MAX. MM	MIN. MM
T010	1.00	34	0	69	29	84	50	119	79
T062	1.59 (1/16")	43	0	78	38	93	50	128	88
T020	2.00	34	0	69	29	84	50	119	79
T093	2.40 (3/32")	40	0	75	35	90	50	125	85
T030	3.00	34	0	69	29	84	50	119	79
T125	3.18 (1/18")	40	0	75	35	90	50	125	85
T040	4.00	34	0	69	29	84	50	119	79

Features

MARKING CAPACITY (IN MILD STEEL)	MODEL RH	MODEL RH
	1 Line of 3 mm Characters 2 Lines of 1/16" Characters	1 Line of 3mm Characters 2 Lines of 1/16" Characters
DIE SLIDE STROKE	125 mm	125 mm
VERTICAL MOVEMENT	40 mm	40 mm
CAPACITY- BASE TO DIE FACE	69 mm	119 mm
HEIGHT	350 mm	400 mm
WIDTH	270 mm	270 mm
LENGTH	320 mm	320 mm
NET WEIGHT	30 kg	33 Kg



ROLLER CRADLES

- ▶ These support and position solid, round components or thick-walled tubing for peripheral marking
- ▶ During the marking operation, the type holder or marking die rolls over the periphery of the component, causing it to rotate in the cradle.

Specifications

ROLLER CRADLE CODE NO.	MODEL RH		MODEL RH	
	USED FOR MARKING DIA. RANGING BETWEEN		USED FOR MARKING DIA. RANGING BETWEEN	
	MIN.	MAX.	MIN.	MAX.
RC 1	6 mm	20 mm	-	-
RC 2	12 mm	35 mm	-	-
RC 3	-	-	25 mm	55 mm



STUD ARBOUR

- ▶ This provides internal support to hollow, round components allowing them to rotate freely during marking.
- ▶ Generally, thin-walled components require close-fitting studs to avoid distortion due to marking: while thick-walled components do not necessarily require close-fitting studs.
- ▶ Hollow, round components with stepped outer diameter can also be marked with the Stud Arbour.



TYPE HOLDERS

- ▶ These guarantee accurate type position, positive locking and durability.



HOLDER CAPACITY - NUMBER OF TYPES (TYPE SIZE MM)

HOLDER CODE NO.	TYPE SIZE (mm)						
	1.00	1.59 (1/16")	2.00	2.40 (3/32")	3.00	3.18 (1/18")	4.00
8 R 10 20	20		10		6		5
8 R 10 40	40		20		13		10
RR 10 60			30		20		15
125 R 10 1000		16					
125 R 10 2000		32					
250 R 10 1000				10		8	
250 R 10 2000				20		16	
250 R 102 L 1000		*24					
250 R 102 L 2000		*56					

SPECIAL ODD SHAPED COMPONENTS ALSO CAN BE MARKED WITH RP - 50 OR RH - 200



BRADMA DIE HARD HYDRAULIC ROLL MARKING MACHINE

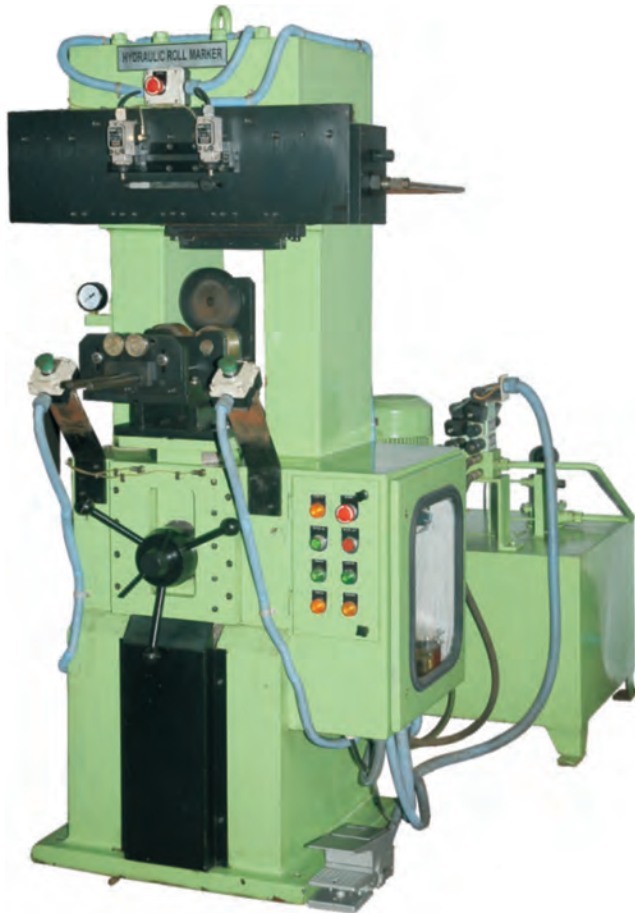

MODEL RH 200



Features

- ▶ Easy to operate
- ▶ Automatic compensation for variation in workpiece diameters.
- ▶ Rigidly fabricated, reinforced steel frame.
- ▶ Stress relieved.
- ▶ Can mark round workpiece upto 200 mm diameter.
- ▶ Can mark flat workpiece upto 170 mm thickness.
- ▶ Open back permits marking of long bars.
- ▶ Serial numbers can be marked with automatic indexing.
- ▶ Can make upto 4 lines of 6 mm characters, or 8 lines of 3mm characters.
- ▶ Ample daylight permits extensive use of fixturing and tooling for almost all shapes and sizes of components.
- ▶ Electrically - controlled hydraulic operations: hydraulic cylinders operate table and marking die slide.
- ▶ Table pressure controls depth of mark : ensuring uniform depth.
- ▶ One master foot-pedal control for operating table and die slide cylinders in proper sequence.
- ▶ Specially designed cylinder fitted with hardened bearing.

COMPONENTS THAT CAN BE MARKED

Shock Absorbers, Flanges, Elbows, Bends, Mortar Barrels, Gears, Fuses, Pistons, Couplings, Railroad Bearings, Shells, Axles, Propeller Shaft s, Rock Drills, Magneto, Lock Body.

ALSO AVAILABLE AGAINST SPECIFIC ORDERS:

SPECIAL PURPOSE MACHINES WHEREIN

- ▶ Daylight can be increased to 425 mm.
- ▶ Stroke can be increased 250 mm.



FOR BETTER RESULTS WE RECOMMEND:

BRADMA DIEHARD TOOLINGS

(Interchangeable Steel Types, Stamp Marks and Holders)

Specifications

Marking Capacity (in Mild Steel)	4 Lines of 6 mm Characters, 6 Lines of 6 mm Characters, 8 Lines of 3 mm Characters
Die Slide Stroke	10 mm
Daylight	285 mm
Throat	90 mm
Open Back	Permits Marking of Long Bars
Open Distance	180 mm Between Up-Rights
Output	Upto 600 Nos. per hour depending on Length of stroke and shape of component
Table Size	250 X 200 mm.
Table Size	10 mm Hydraulically, 110 mm by handwheel.
Table Pressure	1T to 4T
Floor Area	2000 X 2000 mm
Height	1500 mm
Net Weight	850 kg
Motor	3HP, 1500rpm, 440 V, 3-Phase, 50 Cycles
Pump	10 Litres / Min
Hydraulic Tank	75 Litres.

BRADMA DIE HARD PNEUMATIC ROLL MARKING



MODEL RP 50



Features

- ▶ Rugged bench model
- ▶ Automatic compensation for variations in workpiece diameters
- ▶ High production rates. Easy to operate
- ▶ Flat marking, round marking or curved marking
- ▶ Quick set-up time
- ▶ Serial numbers can be marked with automatic indexing
- ▶ Can mark upto 3 lines of 3mm characters
- ▶ All - pneumatic operations: air cyclinders operate table and marking die slide - free from electrical connections.
- ▶ Table pressure controls depth of mark: ensuring uniform depth.
- ▶ One master foot-pedal control: operating table and die slide cylinders in proper sequence
- ▶ Pneumatic filter, regulator and lubricator: provide for direct connection to plant pneumatic supply

COMPONENTS THAT CAN BE MARKED

Gears, Engine Valves, Drills, Taps, Bomb Fuses, Bomb Shells, Sockets, Fuel injection Nozzles, Hose End Fittings, Pneumatic Tools, Axles, Propeller Shafts, Pinions, Cylinder Neck Rings, Squares

- ▶ Thin walled tubular components can be marked using a mandrel fixture with custom - built mandrel to prevent distortion
- ▶ Flat components can be marked using segmental type holder.
- ▶ Solid or thick walled cylindrical components can be marked either by using a roller cradle or special fixture

ALSO AVAILABLE AGAINST SPECIFIC ORDERS: Increased stroke Length of 125 mm can be supplied.

ALSO AVAILABLE: BRADMA DIEHARD
PNEUMATIC ROLL MARKING MACHINE (Model RP 100)
HYDRAULIC ROLL MARKING MACHINE (Model RH 200)

FOR BETTER RESULTS WE RECOMMEND:

BRADMA DIEHARD TOOLINGS (Interchangeable Steel Types, Stamp Marks and Holders)

Specifications

Marking Capacity	3 Lines of 3 mm Characters (In Mild Steel)
Die Slide Stroke	75 mm
Daylight	200 mm
Throat	90 mm
Open Back	75 mm between uprights
Open Distance	180 mm Between Up-Rights
Output	Upto 600 Nos. per hour depending on Length of stroke and of component
Air Consumption	3 Litres / stroke
Table Size	250 X 200 mm.
Table Size	7 mm pneumatically, 160 mm by handwheel.
Table Pressure	1.5T at 5kg / sq cm line pressure
Floor Area	700 X 400 mm
Height	720 mm
Net Weight	240 kg

Tonnage	Model No	Total Travel MM	Power Stroke MM
2 Tonnes	2T 2P 100 T 6PG	100	6
	2T 2P 150 T 6PG	150	6
	2T 4P 100 T 6PG	100	6
	2T 4P 150 T 6PG	150	6
	2T CF 100 T 6PG	100	6
	2T CF 150 T 6PG	150	6
	2T CCF 100 T 6PG	100	6
	2T CCF 150 T 6PG	150	6
4 Tonnes	4T 2P 100 T 6PG	100	6
	4T 2P 150 T 6PG	150	6
	4T 4P 100 T 6PG	100	6
	4T 4P 150 T 6PG	150	6
	4T CF 100 T 6PG	100	6
	4T CF 150 T 6PG	150	6
	4T CCF 100 T 6PG	100	6
	4T CCF 150 T 6PG	150	6
8 Tonnes	8T 2P 100 T 6PG	100	6
	8T 2P 150 T 6PG	150	6
	8T 4P 100 T 6PG	100	6
	8T 4P 150 T 6PG	150	6
	8T CF 100 T 6PG	100	6
	8T CF 150 T 6PG	150	6
	8T CCF 100 T 6PG	100	6
	8T CCF 150 T 6PG	150	6
15 Tonnes	15T 2P 100 T 6PG	100	6
	15T 2P 150 T 6PG	150	6
	15T 4P 100 T 6PG	100	6
	15T 4P 150 T 6PG	150	6
	15T CF 100 T 6PG	100	6
	15T CF 150 T 6PG	150	6
	15T CCF 100 T 6PG	100	6
	15T CCF 150 T 6PG	150	6

Bradma Hydro Pneumatic Presses are recommended for high production rates in marking applications. The ram travels are pneumatically actuated but the marking loads are delivered hydraulically at controlled speed. Hydro Pneumatic Presses are efficient & reliable, low cost & compact alternative to hydraulic power presses and mechanical presses

Salient Features

- ▶ Fast Action : 2T @ 100 cycles / min (CPM), 4T @ 60 CPM, 8T @ 40 CPM, 15T & 30T @ 20 CPM.
- ▶ Compact, Light Weight & Vibration free : Can be mounted on existing work benches without any foundation
- ▶ Versatile : Force & speed can be varied infinitely. Machine can be mounted in any orientation.
- ▶ Energy efficient : 50% to 70% saving over equivalent hydraulic and pneumatic systems.
- ▶ Low cost : Upto 60% cheaper than hydraulic presses.
- ▶ Safety : True, non tie down, interlocked Two Hand Safety operation.

Sequence of Operation

There are three stages of operation

- (a) Initial low force, large travel, fast approach
- (b) High force, short travel (6mm), Power Stroke
- (c) Low force, rapid retraction

The low force approach and retraction at 5 bar air pressure results in upto 70% saving in energy.

BRADMA'S AMS OFFERINGS

PIN MARKING SOLUTIONS



Benchmark 460



TMP 1700

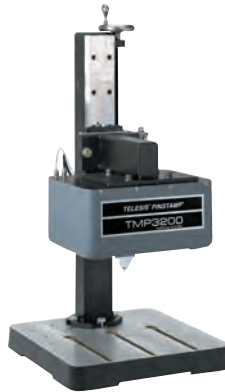

TMP 3200



Benchmark 320

LASER MARKING SOLUTIONS

Fiber Laser



CO₂ Laser



On the Fly Marking



BFL20M Laser Marking

INDUSTRY AUTOMATION



Pin Marking SPM



Billet Feeding SPM



Laser Marking SPM



Frame Marking SPM

DIVISIONAL SALES OFFICES ADDRESS / PH. NO.

AHMEDABAD

1st Floor, Pranvijay Building,
Opp. Bata Showroom, Near Times Of India,
Ashram Road, Ahmedabad - 380009
Telephone: +91 (0) 79 26587769, 079-26580741
Fax: 079-26584618

BENGALURU

Classic Building, 3rd Floor, 24 Richmond Road
Bengaluru - 560025
Telephone: +91 (0) 80 43230129
Fax: +91 (0) 80 43230110

CHENNAI

Catholic Centre, 1st Floor,
108, Armenian Street,
Chennai - 600001
Telephone: +91 (0) 44 25389890/95,
Fax: +91 (0) 44 25360872

NEW DELHI

8F, 8th Floor, Vandana Building,
Tolstoy Marg, New Delhi - 110001
Telephone: +91 (0) 11 43000120/107

KOLKATA

222, Circular Mansion, 1st Floor,
A.J.C. Bose Road,
Kolkata-700 017
Mobile: +91 (0) 70 91193999

MUMBAI

Forbes Building, Charanjit Rai Marg,
Fort, Mumbai 400 001
Telephone: +91 (0) 22 61358958

PUNE

H.No.1195/5, Bhosale Heights, 4th Floor,
Opp. Deendayal Hospital, Fergusson College Road,
Pune 411005
Telephone: +91 (0) 20 48509111

AURANGABAD

B-13, MIDC, Waluj,
Aurangabad - 431133
Telephone: +91 (0) 240 2553422

Forbes & Company Limited

Forbes Building, Charanjit Rai Marg,
Fort, Mumbai 400 001
Telephone: +91 (0) 22 61358958
Email: sales@forbes.co.in
www.bradma-forbes.com